

Student responsibility after using sports education in gymnastics as support for the higher education curriculum in Indonesia

Ade Rahmat^{1ade,*} , Ashadi Cahyadi^{2ade} , & Agi Ginanjar^{2abc} 

IKIP PGRI Pontianak, Indonesia¹
STKIP Nahdlatul Ulama Indramayu, Indonesia²

Received 17 February 2024; Accepted 27 May 2024; Published 28 July 2024
Ed 2024; 9(2): 307-319

ABSTRACT

Background Problems: Responsibility is an important part of studying at the university, such as arriving and doing assignments on time. By using Sport Education (SE), students are given assignments to be responsible for the success of their learning. SE has a strong connection to the Merdeka Belajar-Kampus Merdeka (MBKM) curriculum, with students as the centre of learning. **Research Objectives:** The aim of this research is to find out the responsibilities of each subscale according to the student's role after using SE and to test the effect of using SE on student responsibilities. **Methods:** The research method uses experimentation with a one-shot case study design. The participants involved in this research were 53 students at one of the universities in the sports studies programme in Indramayu who were taken using convenience sampling techniques. The research instrument used was the Contextual Self-Responsibility Questionnaire for sports programme students. The data analysis technique uses statistical descriptions to determine the mean and standard deviation and tests hypotheses using the one-sample t test. **Findings and Results:** The results of this research state that SE has an influence on student responsibility with a t count of 3.81 and Sig. $0.00 < 0.05$. **Conclusion:** This research concludes that there is an influence after using SE on student responsibility, with SE findings that use gymnastics as support for the MBKM curriculum in Indonesia. Further investigation is needed regarding the administration of pretests, the existence of comparison classes, and the development of instruments to facilitate all roles according to the characteristics of roles in SE.

Keywords: Responsibility; sport education; gymnastics; MBKM

 [https://doi.org/10.25299/sportarea.2024.vol9\(2\).16363](https://doi.org/10.25299/sportarea.2024.vol9(2).16363)

OPEN ACCESS 

Copyright © 2024 Ade Rahmat, Ashadi Cahyadi, Agi Ginanjar

Corresponding Author: Ade Rahmat, Department of Physical Education, Postgraduate, IKIP PGRI Pontianak, Pontianak, Indonesia
Email: Mradde16@gmail.com

How to Cite: Rahmat, A., Cahyadi, A., Ginanjar, A. (2024). Student responsibility after using sports education in gymnastics as support for the higher education curriculum in Indonesia. *Journal Sport Area*, 9(2), 307-319. [https://doi.org/10.25299/sportarea.2024.vol9\(2\).16363](https://doi.org/10.25299/sportarea.2024.vol9(2).16363)

Authors' Contribution: a – Study Design; b – Data Collection; c – Statistical Analysis; d – Manuscript Preparation; e – Funds Collection

INTRODUCTION

Responsibility can be a yoke carried by someone in the community to give meaning to life that is accepted consciously; this is in accordance with the situation, not only as an individual but as a person who interacts and is in community with other people (Stengel, 2024). In education, responsibility is not an

educational responsibility created by institutions or a pedagogical responsibility carried out by teachers, but a personal responsibility (Stengel, 2024). Furthermore, responsibility can function both as a goal of teachers' teaching efforts and as an indicator of students' educational success (Stengel, 2024).

Responsibility is very important for students to take part in learning at university. Students are required to have responsibility in completing assignments given by lecturers and their personal assignments; students who have high responsibility will also have high academic achievement index scores (Musa et al., 2019). In the learning process, we find students who do not have responsibilities, such as being late for learning, not completing assignments on time, or even not doing the assigned assignments at all. In line with this, students are still not aware of their responsibilities during lectures (Sobri et al., 2020).

To better assess student responsibilities, it is necessary to conduct large-scale research based on a larger sample size. Therefore, the development of reliable and valid instruments to assess student responsibility is necessary. The instrument that measures responsibility among the Contextual Self-Responsibility Questionnaire (CSRQ) consists of three subscales, namely: care for others/goal setting (CO), self-responsibility (SR), and self-control/respect (SC), which was developed by Watson et al. (2003) with a total of 15 items that were originally intended to address adolescent responsibilities in physical education (PE).

CO relates to fun, interest in sports, and respect for their friends and group leaders (Watson et al., 2003). SR relates to personal responsibility for the tasks given either by the lecturer or with the goals that have been set (Watson et al., 2003). SC relates to the extent to which students are able to control their behaviour and are able to respect their friends and group leaders (Watson et al., 2003). Although research instruments have been used in several studies, Re-examination of the factorial structure through an empirical approach is still needed in the Indonesian version, and to date, there has been no research that conceptually tests CSRQ dimensions with an empirical approach in the Indonesian version at the university level using confirmatory factor analysis (CFA).

In this research, the author tried to apply a learning strategy that he felt was suitable for improving the quality of learning towards student responsibilities. One of the learning strategies that will be implemented is sport education (SE). SE has similarities with the expectations of the Merdeka Belajar-Kampus Merdeka (MBKM) curriculum, referring to outcome-based education (OBE) (Dirjendikti Kemdikbud RI, 2020; Hatmanto, 2020). OBE must be aligned with predetermined learning outcomes (Ginanjar et al., 2022; Gurukkal, 2020), teaching methods, student-centred learning, pedagogical interventions, and evaluation parameters to produce strong and meaningful learning, not just getting a degree (Ginanjar et al., 2022). Further, students who hold a degree are competent in the application and use of the knowledge they have acquired (Japee & Oza, 2021).

Therefore, to be able to achieve these expectations, the role of students is very important, and they have a very big responsibility with the help of lecturers as facilitators of learning. Apart from that, it is also indicated that there is a connection between OBE, which underlies the MBKM curriculum, and the implementation of SE in sports study programmes (Ginanjar et al., 2022). Apart from that, it is recommended that SE be included as part of the sports studies programme curriculum (Agustin et al., 2024; Effendy & Ramadhan, 2021; Ramadhan et al., 2024).

SE is a curriculum model that can be widely developed by teachers for use in various forms of sports activities (Ginanjar et al., 2021) through six characteristics: season, affiliation, formal competition, culminating event, keeping records, and festivity (Ginanjar et al., 2021). The aim of SE is that someone involved in SE will become someone who has competence related to sports skills and knowledge, becomes an athlete who is sports literate, and is enthusiastic about participating in sports activities (Ginanjar, Kharisma, et al., 2021). In line with this, the goal of SE will be someone who is literate, enthusiastic, and competent (Siedentop, 1994; Siedentop et al., 2011).

The most interesting characteristic in SE is related to the existence of competition or tournament activities at the end of the learning season, with the roles involved such as coaches, managers, players, referees, match recorders, and publications (Ginanjar et al., 2021). With the existence of roles during learning using SE, it is certain that each student must have responsibility for carrying out learning using SE throughout the season.

Students who are given responsibility for developing and implementing SE take the task more seriously and are more likely to take responsibility for the success of the season (Siedentop et al., 2011).

In Indonesia, not too much SE research has been carried out at universities. The search results only included seven SE studies at universities, but it has been stated that SE can be used in learning at universities (Effendy & Ramadhan, 2021; Ginanjar et al., 2023; Ginanjar, Mubarak, et al., 2021a; Purwanto et al., 2014; Slamet, 2018; Slamet et al., 2021; Solihin et al., 2022). Regarding SE towards responsibility in universities, especially in Indonesia, it has been stated that SE raises student responsibilities (Purwanto et al., 2014), but it is not discussed clearly and is only an observation of learning outcomes without any instruments with evidence of validity and reliability that can prove it. Thus, there is a gap in whether SE influences student responsibilities. At the junior high school level (Wulandari & Hendrayana, 2021) and high school (Anwar, 2016; Anwar et al., 2019). SE for responsibility has been carried out and has had an impact using basketball, but both studies are from programmes and instruments whose use is not clearly discussed.

Based on everything that has been explained in this research, we will use gymnastics, which is an individual sport, to learn to use SE. This is different from previous research, which used basketball (Effendy & Ramadhan, 2021), futsal (Ginanjar et al., 2023; Ginanjar et al., 2021a; Solihin et al., 2022), and handball (Slamet, 2018; Slamet et al., 2021), which is more of a team sport. Thus, whether SE uses gymnastics can influence students' responsibilities. The aim of this research is to find out the responsibilities of each subscale according to the student's role after using SE, with the specific aim of testing the effect of using SE on student responsibilities.

METHOD

The research method uses experimentation with a one-shot case study design. In a one-shot case study design, one group is exposed to a treatment or event, and the dependent variable is then observed to assess the effects of the treatment (Fraenkel et al., 2023).

Participants

The participants involved in this research were 53 students taking curriculum courses in one of the sports study programmes in Indramayu, who were taken using a convenience sampling technique. Convenience sampling is a group of individuals who are willing to be researched to learn (Fraenkel et al., 2023). Apart from that, this is also related to permission given by the lecturer in charge of the course with the approval of the head of the study programme.

Sport Education Gymnastics Program

SE treatment is given in 15 lessons. The SE programme uses an SE gymnastics season with three phases, namely: skill/tactical development, inter/intra team games with practices, and postseason (Ginanjar et al., 2021; Ginanjar et al., 2021b). As previously explained in SE, there are roles involved, such as coach, manager, player, referee, match recorder, and publication. According to SE characteristics, coaches, managers, and players are part of the In-Team Roles (ITR), and referees, match recorders, and publications are part of the Out-Team Roles (OTR) (Ginanjar et al., 2021a).

There are four teams involved, each consisting of one coach, one manager, and nine players. In total, there are 4 people who are coaches, 4 people who are managers, and 36 people who are players. The four teams were assisted in documenting when the teams practiced and competed by one publication person; a total of four people became publications. Three people become referees, and the remaining two become match recorders. For treatment, see Table 1.

Table 1. SE Gymnastics

Phase	Season	Learning materials
Skill/ tactical development	1	<ul style="list-style-type: none"> • Introduction to gymnastics • Role selection • Team selection and team name • Role rules and role contracts

Phase	Season	Learning materials
Inter/ intra team games with practices	2	<p>ITR</p> <p>Technical training or tactical training</p> <ul style="list-style-type: none"> • Coach = reports on training programs and provides training programs to players • Manager = role contract reports, prepares team needs, assists coaches, and is absent for the entire team • Players = train according to the coach instructions <p>OTR</p> <ul style="list-style-type: none"> • Referee = prepares match rules • Match recorder = compiling match sheets • Publications = reporters of team training activities and news reports on social media
	3	<p>ITR</p> <p>Technical training or tactical training</p> <ul style="list-style-type: none"> • Coach = reports on training programs and provides training programs to players • Manager = team profile reports, preparing team needs, assisting the coach, and absences for the entire team • Players = train according to the coach instructions <p>OTR</p> <ul style="list-style-type: none"> • Referee = continuation of preparation of match rules • Match recorder = continuation of compiling match sheets • Publications = reporters of team training activities and news reports on social media
	4	<p>ITR</p> <p>Technical training or tactical training</p> <ul style="list-style-type: none"> • Coach = reports on training programs and provides training programs to players • Manager = preparing team needs, assisting the coach, and absences for the entire team • Players = train according to the coach instructions <p>OTR</p> <ul style="list-style-type: none"> • Referee = report on the preparation of match rules • Match recorder = match sheet preparation report • Publications = reporters of team training activities and news reports on social media
	5	<p>ITR</p> <p>Technical training or tactical training</p> <ul style="list-style-type: none"> • Coach = reports on training programs and provides training programs to players • Manager = preparing team needs, assisting the coach, and absences for the entire team • Players = train according to the coach instructions <p>OTR</p> <ul style="list-style-type: none"> • Referee = coordinates with the match recorder to prepare the match system • Match recorder = coordinates with the referee to prepare the match system • Publications = reporters of team training activities and news reports on social media
	6	<p>ITR</p> <p>Team training and trials between players in the team</p> <ul style="list-style-type: none"> • Coach = reports on training programs and provides training programs to players • Manager = preparing team needs, assisting the coach, and absences for the entire team • Players = train according to the coach instructions <p>OTR</p> <ul style="list-style-type: none"> • Referee = continuation of the preparation of the match system • Match recorder = continuation of the preparation of the match system • Publications = reporters of team training activities and news reports on social media
	7	<p>ITR</p> <p>Team training and trials between players in the team</p> <ul style="list-style-type: none"> • Coach = reports on training programs and provides training programs to players • Manager = preparing team needs, assisting the coach, and absences for the entire team • Players = train according to the coach instructions <p>OTR</p> <ul style="list-style-type: none"> • Referee = match system report • Match recorder = match system report • Publications = reporters of team training activities and news reports on social media
	8	ITR

Phase	Season	Learning materials
Postseason	9	Team training and trials between players in the team
		<ul style="list-style-type: none"> • Coach = reports on training programs and provides training programs to players • Manager = preparing team needs, assisting the coach, and absences for the entire team • Players = train according to the coach instructions
		OTR
	10	<ul style="list-style-type: none"> • Referee = coordinates with the match recorder for the preparation of technical meetings • Match recorder = coordinates with the referee to arrange technical meetings • Publications = reporters of team training activities and news reports on social media
		ITR
		Team training and trials between players in the team
	11	<ul style="list-style-type: none"> • Coach = reports on training programs and provides training programs to players • Manager = preparing team needs, assisting the coach, and absences for the entire team • Players = train according to the coach instructions
		OTR
		<ul style="list-style-type: none"> • Referee = technical meeting report • Match recorder = technical meeting report • Publications = reporters of team training activities and news reports on social media
	12	ITR
		Technical meeting
		<ul style="list-style-type: none"> • Coach = competition participant • Manager = competition participant and absences for the entire team • Players = competition participant
	13	OTR
		<ul style="list-style-type: none"> • Referee = competition committee • Match recorder = competition committee • Publications = reporters and news reports on social media
		ITR
14	Post-season tournament	
	<ul style="list-style-type: none"> • Coach = prepare the team to compete • Manager = preparing team needs, assisting the coach, and absences for the entire team • Players = compete 	
	OTR	
15	<ul style="list-style-type: none"> • Referee = officiating the match • Match recorder = record match results • Publications = reporters, commentator, and news reports on social media 	
	ITR	
	Final - Celebrations and awards	
	<ul style="list-style-type: none"> • Coach = prepare the team to compete • Manager = preparing team needs, assisting the coach, and absences for the entire team • Players = compete 	
	OTR	
	<ul style="list-style-type: none"> • Referee = officiating the match • Match recorder = record match results • Publications = reporters, commentator, and news reports on social media 	

Research Instrument

The research instrument uses the CSRQ developed by [Watson et al. \(2003\)](#), which consists of three subscales, namely: CO, SR, and SC. Each subscale consists of five test items, for a total of 15 items. As previously explained, the original version of the CSRQ uses English and is intended to measure PE youth's responsibility. In accordance with research needs to find out students responsibilities at the university, the research again validated the instrument using CFA on sports programme students, involving 167 students outside the participants involved in this research who were analysed using the help of the AMOS application.

The development of CRSQ follows the theory proposed by [Azwar \(2016\)](#) with the following stages: (i) item writing rules; (ii) expert appraisal; (iii) pilot study; and (iv) second expert appraisal. This validation stage is almost the same as that carried out by ([Ginanjari et al., 2024](#)). The rules for writing items are related to the original version of the CRSQ, which was translated into Indonesian with the help of a lecturer from the English study programme at one of the universities in Indramayu. The translation results from the original version to the Indonesian version can be seen in Table 2.

Table 2. CRSQ Translation Results for Sports Programme Students

Original Version			Indonesian version		
Scale	No. test items	Test items	Scale	No. test items	Test items
Care for Others/ Goal Setting	1	I was concerned for others.	<i>Peduli orang lain/ penetapan tujuan</i>	1	<i>Saya mengkhawatirkan orang lain.</i>
	2	I set goals.		2	<i>Saya menetapkan tujuan.</i>
	3	I supported the other kids in my group.		3	<i>Saya mendukung anak-anak di kelompok saya.</i>
	4	I was able to set goals.		4	<i>Saya dapat menetapkan tujuan.</i>
	5	I listened to other kids in my group.		5	<i>Saya mendengarkan anak-anak di kelompok saya,</i>
Self-Responsibility	6	I participated even when i didn't want to.	<i>Tanggung jawab diri</i>	6	<i>Saya ikut berpartisipasi bahkan ketika saya tidak menginginkannya.</i>
	7	I practiced on my own.		7	<i>Saya berlatih sendiri.</i>
	8	I took responsibility for what I did.		8	<i>Saya mengambil tanggung jawab atas apa yang saya lakukan.</i>
	9	I tried to do what the coach said		9	<i>Saya mencoba melakukan apa yang dikatakan pelatih.</i>
	10	I tried hard.		10	<i>Saya berusaha keras.</i>
Self-Control/ Respect	11	I was able to control what I did.	<i>Kontrol diri/ rasa hormat</i>	11	<i>Saya dapat mengendalikan apa yang saya lakukan.</i>
	12	I controlled my behavior.		12	<i>Saya dapat mengendalikan perilaku saya.</i>
	13	I didn't lose my temper; I kept my cool.		13	<i>Saya tidak kehilangan kesabaran; saya tetap tenang.</i>
	14	I made fun of some of the other kids.		14	<i>Saya mengolok-olok beberapa anak lain.</i>
	15	I respected others.		15	<i>Saya menghormati orang lain.</i>

An Indonesian language expert appraisal was asked to check the translation results for suitability for Enhanced Indonesian Spelling (EIS) involving two lecturers in the Indonesian language study programme at a university in Indramayu. The results obtained, in accordance with the results of discussions with Indonesian language experts and adapted to research needs at the university level, can be seen in Table 3.

Table 3. Results of Discussions with Indonesian Language Experts on CRSQ for Sports Programme Students

Indonesian version		
Scale	No. test items	Test items
<i>Peduli orang lain/ penetapan tujuan</i>	1	<i>Saya khawatir dengan teman atau tim saya dalam mengikuti perkuliahan</i>
	4	<i>Saya menetapkan tujuan dalam mengikuti perkuliahan</i>
	7	<i>Saya mendukung teman-teman lain dalam kelompok saya dalam mengikuti perkuliahan</i>

Indonesian version		
Scale	No. test items	Test items
Tanggung jawab diri	10	Saya mampu menetapkan tujuan dalam mengikuti perkuliahan
	13	Saya mendengarkan teman-teman dalam kelompok saya dalam mengikuti perkuliahan
	2	Saya berpartisipasi bahkan ketika saya tidak mau mengikuti perkuliahan
	5	Saya berlatih sendiri untuk menghadapi perkuliahan
	8	Saya bertanggung jawab atas apa yang saya lakukan dalam mengikuti perkuliahan
	11	Saya mencoba melakukan apa yang dikatakan dosen dalam mengikuti perkuliahan
Kontrol diri/ rasa hormat	14	Saya berusaha keras dalam mengikuti perkuliahan
	3	Saya bisa mengendalikan apa yang saya lakukan dalam mengikuti perkuliahan
	6	Saya dapat mengendalikan perilaku saya dalam mengikuti perkuliahan
	9	Saya tidak marah dan tetap tenang dalam mengikuti perkuliahan
	12	Saya mengolok-olok beberapa teman lain dalam mengikuti perkuliahan
	15	Saya menghormati teman saya dalam mengikuti perkuliahan

The first expert appraisal was asked to check the wording of each test item, which involved two lecturers in the sports study programme at one of the universities in Indramayu who had experience using SE. The results of the two experts were calculated using Aiken's V coefficient calculation, and all items met the requirements of 0.70. The trial was carried out on 20 students in the students in the sports study programme who had been taught using SE related to understanding each sentence of each test item, and all students understood each sentence in each test item. They were not involved as research participants, nor were there 167 student participants. The results obtained from 20 students showed that they understood each sentence in each question item.

The results of the trial were then validated again by a second expert appraisal to check the wording of each test item involving three lecturers in the sports study programme at one of the universities in Indramayu who had experience using SE, the same as what had been done in the first expert appraisal. The results of the three experts were calculated using Aiken's V coefficient calculation, and all items had a requirement of 0.70.

After the analysis, 10 test items can be used: 4 test items on CO, 3 test items on SR, and 3 test items on SC with CMIN = 64.03 and DF = 32, RMSEA = 0.078 between 0.050 and 0.080 with NFI, PNFI, CFI, IFI, RFI, GFI, and AGFI, with respectively 0.95, 0.68, 0.97, 0.97, 0.93, 0.93, and 0.88 indicated as acceptable and Structural Equation Modelling (SEM) is good. For more details, see Figure 1, and the form of the CRSQ instrument for sports programme students can be seen in Table 4.

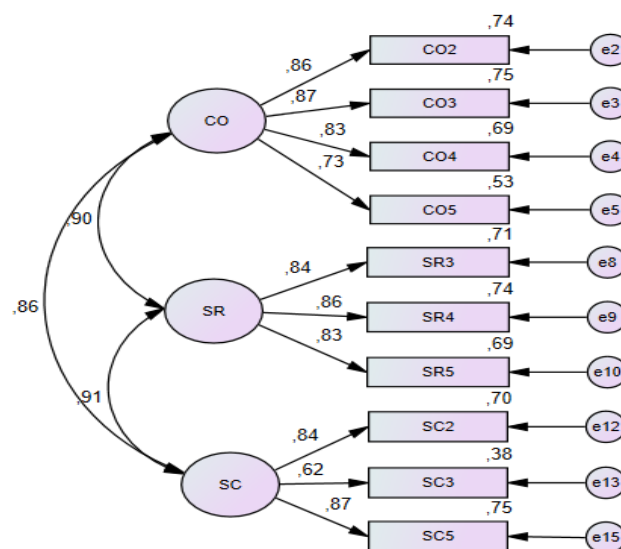

Figure 1. SEM CRSQ

Table 4. CRSQ for Sports Programme Students

Scale	No. test items	Test items
<i>Peduli orang lain/penetapan tujuan</i>	1	<i>Saya menetapkan tujuan dalam mengikuti perkuliahan</i>
	4	<i>Saya mendukung teman-teman lain dalam kelompok saya dalam mengikuti perkuliahan</i>
	7	<i>Saya mampu menetapkan tujuan dalam mengikuti perkuliahan</i>
	10	<i>Saya mendengarkan teman-teman dalam kelompok saya dalam mengikuti perkuliahan</i>
<i>Tanggung jawab diri</i>	2	<i>Saya bertanggung jawab atas apa yang saya lakukan dalam mengikuti perkuliahan</i>
	5	<i>Saya mencoba melakukan apa yang dikatakan dosen dalam mengikuti perkuliahan</i>
	8	<i>Saya berusaha keras dalam mengikuti perkuliahan</i>
<i>Kontrol diri/ rasa hormat</i>	3	<i>Saya dapat mengendalikan perilaku saya dalam mengikuti perkuliahan</i>
	6	<i>Saya tidak marah dan tetap tenang dalam mengikuti perkuliahan</i>
	9	<i>Saya menghormati teman saya dalam mengikuti perkuliahan</i>

Data Analysis Technique

The data analysis technique uses statistical descriptions to determine the mean (M) and standard deviation (SD), as well as hypothesis testing using a one-sample t test using the SPSS application, which is analysed following the calculation procedure according to (Ginanjari, 2021). In accordance with the design and data analysis techniques used, the researcher determined the constant value related to CRSQ for sports programme students at $M = 4$ using a benchmark assessment of 80%, which was adjusted to the B value in the assessment in the study programme used in this research. The constant value comes from 10 test items according to the research instrument used, with a maximum score of 50 and $M = 5$. For the constant value of the benchmark assessment, the CRSQ for sports programme students can be seen in Table 5.

Table 5. Constant Value for Benchmark Assessment in CRSQ for Sports Programme Students

Percentage	Range	Value
100%	5	100
90%	4.5	90
80%	4	80
70%	3.5	70
60%	3	60
50%	2.5	50
40%	2	40
30%	1.5	30
20%	1	20
10%	0.5	10

RESULTS AND DISCUSSION

The overall results of the data analysis were $M = 4.30$ and $SD = 0.78$. Meanwhile, for each subscale, CO obtained $M = 4.22$ and $SD = 0.79$. SR obtained $M = 4.40$ and $SD = 0.74$. SC obtained $M = 4.30$ and $SD = 0.79$.

Table 6. Statistical Descriptions for Subscales on the CRSQ for Sports Programme Students

Variable	M	SD
CO	4.22	0.79
SR	4.40	0.74
SC	4.30	0.79
General	4.30	0.78

For the results of the analysis of responsibility for each subscale according to the student's role after using SE, as seen from M. Coaches CO = 4.13, SR = 4.25, and SC = 4.17. Managers CO = 4.50, SR = 4.67, and SC = 4.67. Players CO = 4.31, SR = 4.45, and SC = 4.37. Referees CO = 3.92, SR = 4.67, and SC = 4.22. Match recorders CO = 4.50, SR = 4.67, and SC = 4.33. Publications CO = 3.44, SR = 3.50, and SC = 3.42. To be clearer about the differences in results for each role in each subscale, it can be seen in Figure 2.

Meanwhile, as a whole, it can be seen from M for each role: coaches = 4.18, managers = 4.61, players = 4.38, referees = 4.27, match recorders = 4.50, and publications = 3.45. For more details, see Figure 3.

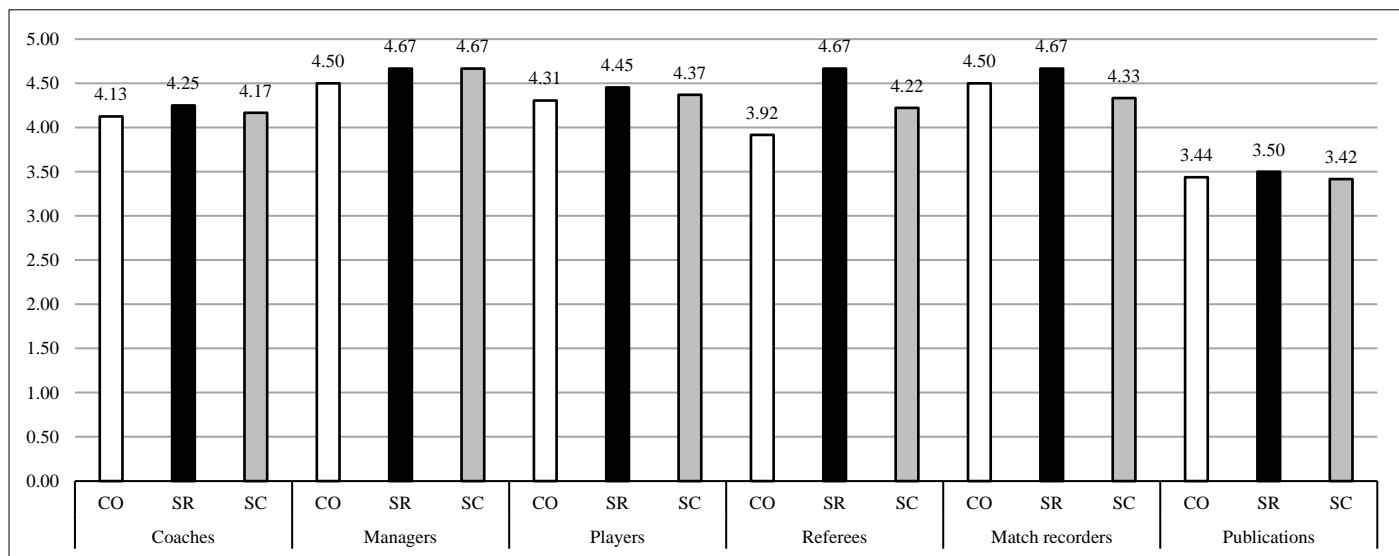

Figure 2. Mean Responsibility of Each Subscale According to Roles

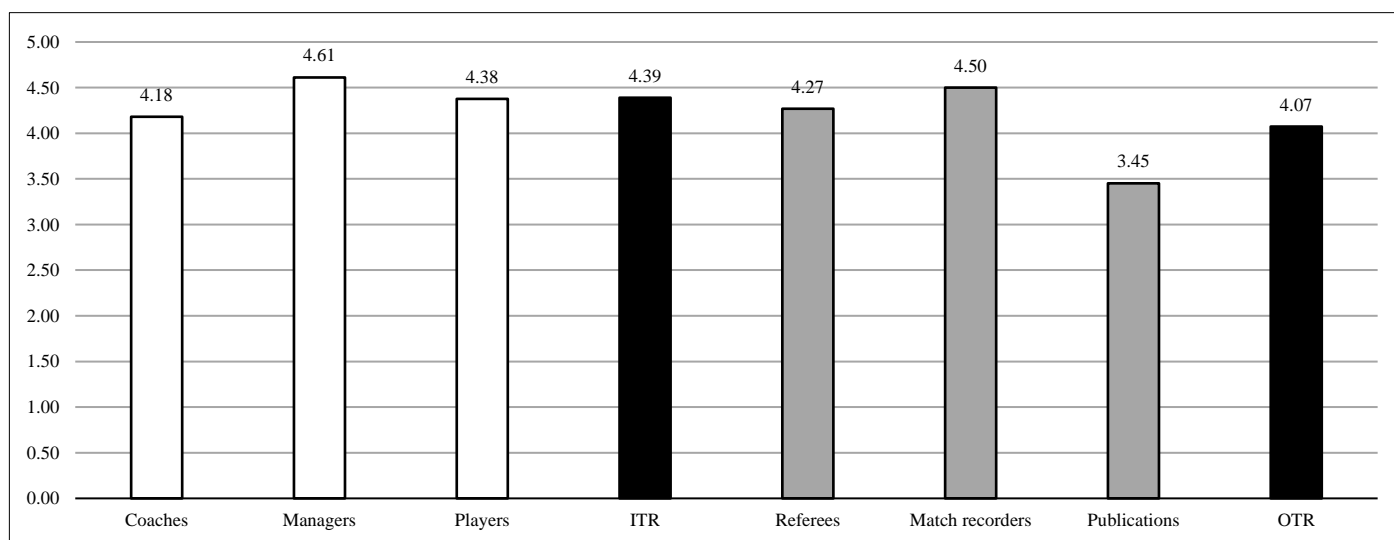

Figure 3. Mean Responsibility for Each Role

To test the hypothesis of the effect of using SE on student responsibility. Obtained t count = 3.81 with Sig. 0.00 < 0.05, which means there is an influence after using SE on student responsibility. For more details, see Table 7.

Table 7. One-Sample t test

Variable	t count	Sig.
Responsibility	3.81	0.00

Responsibility according to the students' role in each subscale

From the results that have been presented, it can be seen in Figure 2 that each role involved depends on the subscale that is more influenced by SR. This is in line with the statement that SR has a positive relationship with enjoyment, interest in sports, and respect for leaders (Watson et al., 2003). For example, when a team is training led by a coach, the players carry out their roles according to the instructions of the coach, who is also accompanied by a manager. In line with the statement that effective interventions are

found in developing coach (student as coach) pedagogy to students (students as players) that allows the transfer of instructional responsibility (Araújo et al., 2017), peer learning occurs when students share responsibility for their team's success (Farias et al., 2018; Manninen & Campbell, 2022), which shifts responsibility to students and improves play by focusing on tactical issues (Stran et al., 2012).

Then, the role of coaches, managers, and players who coordinate with each other in a team, or what can be called ITR, also provides excellent responsibility, which leads to personal and social responsibility. This is in line with the statement that SE, with its emphasis on persistent team membership, promotes personal and social development in the form of student responsibility (Wallhead & O'sullivan, 2005) and is directly related to personal and social responsibility (García-López & Gutiérrez, 2015; Menendez-Santuri & Fernandez-Rio, 2017).

However, if you look at the constant value that has been set at 4, it is then linked to the results of overall responsibility for each role involved. In the roles of coaches, managers, players, referees, and match recorders, they have provided the expected results and exceeded these expectations. Meanwhile, the role of publications has not been able to achieve the expected results because it is still below the constant value.

This seems to be due to the publication's role; they carry out their role independently; they serve as reporters, commentators, and newsmakers to fulfil their duties and have no responsibility for the running of the competition. Unlike coaches and managers, players in a team practice and are ready to take part in competitions. Likewise, the role of referees and match recorders is to coordinate with each other and prepare the competition to run smoothly from the start to the end of the competition.

Apart from that, this can also be caused by the lack of space for questions or statements from the instruments used because it facilitates roles that are closely related within a team, such as the roles of coaches, managers, and players who become one unit in a team. Likewise, referees and match recorders, who often coordinate as a team as a competition committee, These results can also be an indication that, ultimately, they can lead to better ITR responsibilities compared to OTR.

The effect of using SE on students' responsibility

This research states that there is an influence after using SE on student responsibility. Thus, this research provides new images and findings that SE can be used to see student responsibilities during the learning process. It is also proven that all students can fulfil all the tasks that have been given according to their roles. Like a coach who creates and implements training programmes and prepares his team to take part in competitions. Managers who assist coaches in both training and matches, create contracts and team profiles, and record absences. Players who follow instructions from coaches who are assisted by managers. The referee coordinates with the match recorders to ensure the competition runs smoothly from start to finish. Publications that become reporters, commentators, make news, and post on social media, even though the results of their responsibilities have not been in accordance with what was expected,.

This research also supports the results of research conducted at the university level that SE can be used in learning at the university level, especially in Indonesia (Effendy & Ramadhan, 2021; Ginanjar et al., 2023; Ginanjar et al., 2021a; Purwanto et al., 2014; Slamet, 2018; Slamet et al., 2021; Solihin et al., 2022). Apart from that, this research also supports that SE influences students' responsibilities during the learning process (Anwar, 2016; Anwar et al., 2019; Wulandari & Hendrayana, 2021), although at different levels.

Regarding the ongoing MBKM curriculum, this research also suggests and supports that SE can be used as a learning strategy with its role as an emphasis on student responsibility while following the learning process, which is closely related to the MBKM curriculum. In line with this, SE has shown the curriculum model to be effective in motivating students to undertake specific role responsibilities and engage in student-led tasks (Wallhead & O'sullivan, 2007).

Furthermore, there is a link between OBE, which underlies the MBKM curriculum, and the implementation of SE in sports study programmes (Ginanjar et al., 2022), which can help develop the MBKM curriculum (Ginanjar et al., 2024). SE can be used as a basis for programme curricula, especially those related to sports (Agustin et al., 2024; Effendy & Ramadhan, 2021), which is very student-centred with

the various roles involved (Ramadhan et al., 2024), and is appropriate to be developed by stakeholders in schools and other institutions (Slamet et al., 2021).

CONCLUSION

This research concludes that there is an influence after using SE on student responsibility, with SE findings that use gymnastics and as support for the MBKM curriculum in Indonesia. The responsibilities of each subscale according to the student's role after using SE are in line with expectations, except for the publication role. Further investigation is needed regarding the administration of the pretest and the existence of a comparison class so that the findings obtained can be generalized. It is necessary to develop instruments to facilitate each test item by taking into account the characteristics of all roles involved.

This research still has weaknesses compared to what has been presented. Apart from that, there was no pretest in this study. This could be because when the treatment took place, the instrument was still in the validation stage. The absence of a comparison class is also a weakness in this research. The instrument needs to be re-validated in order to better facilitate questions or statements for each test item by taking into account the characteristics of all roles involved in accordance with SE characteristics.

ACKNOWLEDGEMENTS

The author would like to thank the Chair of the Department of Physical Education, Health, and Recreation, STKIP Nahdlatul Ulama Indramayu, and the Chair of Postgraduate Physical Education, IKIP PGRI Pontianak, who have provided recommendations and permission to conduct research.

CONFLICT OF INTEREST

The authors declared no conflict of interest.

REFERENCES

- Agustin, N. M., Mudzakir, D. O., & Fadilah, D. N. (2024). Students' Leadership Level after Badminton Sports Education Learning. *Indonesian Journal of Physical Education and Sport Science*, 4(1), 31–39. <https://doi.org/10.52188/ijpess.v4i1.520>
- Anwar, A. S. (2016). Pengaruh Model Sport Education Terhadap Sikap Tanggung Jawab dan Kemandirian Siswa. *Jurnal Sekolah Dasar*, 1(1), 155–175. <https://doi.org/10.36805/jurnalsekolahdasar.v1i1.68>
- Anwar, A. S., Hendrayana, Y., & Ma'mun, A. (2019). The Development of Responsibility and Leadership Through Sport Education Model. *4th International Conference on Sports Science, Health and Physical Education*, 21, 183–188. <https://doi.org/10.2991/ahsr.k.200214.049>
- Araújo, R. M. F., Hastie, P. A., Pereira, C. H. de A. B., & Mesquita, I. M. R. (2017). The Evolution of Student-Coach's Pedagogical Content Knowledge in a Combined use of Sport Education and the Step-Game-Approach Model. *Physical Education and Sport Pedagogy*, 22(5), 518–535. <https://doi.org/10.1080/17408989.2017.1294668>
- Azwar, S. (2016). *Penyusunan Skala Psikologi*. Pustaka Pelajar.
- Dirjendikti Kemdikbud RI. (2020). *Buku Panduan Merdeka Belajar-Kampus Merdeka* (1st ed.). Direktorat Jenderal Pendidikan Tinggi Kemdikbud RI.
- Effendy, F., & Ramadhan, R. (2021). College Students Sport Orientation after Following Basketball Sport Education. *KINESTETIK: Jurnal Ilmiah Pendidikan Jasmani*, 5(3), 518–526. <https://doi.org/10.33369/jk.v5i3.17334>

- Farias, C., Valério, C., & Mesquita, I. (2018). Sport Education as a Curriculum Approach to Student Learning of Invasion Games: Effects on Game Performance and Game Involvement. *Journal of Sports Science and Medicine*, 17(1), 56–65. <https://www.jssm.org/researchjssm-17-56.xml.xml#>
- Fraenkel, J. R., Wallen, N. E., & Hyun, H. H. (2023). *How to Design and Evaluate Research in Education*. McGraw Hill-Inc.
- García-López, L. M., & Gutiérrez, D. (2015). The Effects of a Sport Education Season on Empathy and Assertiveness. *Physical Education and Sport Pedagogy*, 20(1), 1–16. <https://doi.org/10.1080/17408989.2013.780592>
- Ginanjar, A. (2021). *Statistika Terapan Dalam Pendidikan Jasmani & Olahraga: Aplikasi Microsoft Excel & SPSS*. Deepublish.
- Ginanjar, A., Burgueño, R., Ramadhan, R., & Larasaty, G. (2024). Validation of the Sport Education Scale for Higher Education Students in the Indonesian Version. *Journal Sport Area*, 9(1), 43–54. [https://doi.org/10.25299/sportarea.2024.vol9\(1\).14424](https://doi.org/10.25299/sportarea.2024.vol9(1).14424)
- Ginanjar, A., Kharisma, Y., Ramadhan, R., & Effendy, F. (2021). *Mengetahui, Mengenal, Mempraktikkan, dan Merancang Sport Education Menggunakan Cabang Olahraga Bola Voli*. Deepublish.
- Ginanjar, A., Mubarak, M. Z., & Mudzakir, D. O. (2021a). “College Students” Motivation after Teaching Using Sport Education Season. *International Journal of Human Movement and Sports Sciences*, 9(4A), 1–7. <https://doi.org/10.13189/saj.2021.091301>
- Ginanjar, A., Mubarak, M. Z., & Mudzakir, D. O. (2021b). *Mengetahui, Mengenal, Mempraktikkan, dan Merancang Sport Education Menggunakan Cabang Olahraga Futsal*. Program Studi Pendidikan Jasmani Kesehatan dan Rekreasi STKIP Nahdlatul Ulama Indramayu.
- Ginanjar, A., Mubarak, M. Z., Mudzakir, D. O., Kharisma, Y., Ramadhan, R., Effendy, F., Setiawan, A., Oktriani, S., Agustin, N. M., & Bahri, S. (2022). Outcome Based Education dalam Kurikulum Merdeka Belajar Kampus Merdeka “Sejalankah dengan Sport Education?” *Seminar Nasional Pendidikan Jasmani, Kesehatan dan Rekreasi, Fakultas Ilmu Keolahragaan, Universitas Negeri Malang 2022: Optimalisasi Pelaksanaan Pendidikan Jasmani, Olahraga, dan Kesehatan Melalui Merdeka Belajar*, 1–12.
- Ginanjar, A., Ramadhan, R., Effendy, F., Kharisma, Y., & Agustin, N. M. (2023). The Effect of Sport Education Season Futsal on College Student Sport Orientation. *International Journal of Human Movement and Sports Sciences*, 11(4), 914–925. <https://doi.org/10.13189/saj.2023.110428>
- Gurukkal, R. (2020). Outcome-Based Education: An Open Framework. *Higher Education for the Future*, 7(1), 1–4. <https://doi.org/10.1177/2347631119886402>
- Hatmanto, E. D. (2020). *Guided Book Preparation of an OBE Curriculum Oriented of Merdeka Belajar Kampus Merdeka*. Education Development Office of Universitas Muhammadiyah Yogyakarta.
- Japee, G. P., & Oza, P. (2021). Curriculum and Evaluation in Outcome-Based Education. *Psychology and Education Journal*, 58(2), 5620–5625. <https://doi.org/10.17762/pae.v58i2.2982>
- Manninen, M., & Campbell, S. (2022). The Effect of the Sport Education Model on Basic Needs, Intrinsic Motivation and Prosocial Attitudes: A Systematic Review and Multilevel Meta-Analysis. *European Physical Education Review*, 28(1), 78–99. <https://doi.org/10.1177/1356336X211017938>
- Menendez-Santuri, J., & Fernandez-Rio, J. (2017). Teachers and Students’ Perceptions of a Hybrid Sport Education and Teaching for Personal and Social Responsibility Learning Unit. *Journal of Teaching in Physical Education*, 36(2). 185-196. <https://doi.org/10.1123/jtpe.2016-0077>

- Musa, M., Sukur, A., & Fitranto, N. (2019). Korelasi Sikap Disiplin dan Tanggung Jawab Terhadap Indeks Prestasi Akumulatif Mahasiswa Fakultas Ilmu Olahraga Peserta Kegiatan Outdoor Based Character Building (OBCB). *Jurnal Ilmiah Sport Coaching and Education*, 3(2), 164–172. <https://doi.org/10.21009/jsce.03218>
- Purwanto, S., Susanto, E., & Pahalawidi, C. (2014). Pendidikan Karakter dengan Pendekatan Sport Education dalam Perkuliahan di Jurusan Pendidikan Olahraga UNY. *Jurnal Pendidikan Karakter*, 4(1), 48–60. <https://doi.org/10.21831/jpk.v0i2.2176>
- Ramadhan, R., Effendy, F., & Pratama, A. P. (2024). Sports Education on Student Learning Motivation Seen from the Roles Involved in Sport Education Using Handball. *Indonesian Journal of Physical Education and Sport Science*, 4(1), 22–30. <https://doi.org/10.52188/ijpess.v4i1.511>
- Siedentop, D. (1994). *Sport education: quality PE through positive sport experiences*. Human Kinetics.
- Siedentop, D., Hastie, P. A., & Mars, H. van der. (2011). *Complete Guide to Sport Education*. Human Kinetics.
- Slamet, S. (2018). Theoretical and Empirical Review on Sport Education Model (SEM) and Physical Self Concept (PSC) in Game Activities in Schools. *3rd International Conference on Sports Science, Health and Physical Education*, 11, 375–378. <https://doi.org/10.2991/icsshpe-18.2019.103>
- Slamet, S., Yudiana, Y., Mahendra, A., & Ma'mun, A. (2021). Leadership and Handball Game Performance through Sport Education Model. *Jurnal Pendidikan Jasmani Dan Olahraga*, 6(1), 121–128. <https://doi.org/10.17509/jpjo.v6i1.30126>
- Sobri, M., Nursaptini, & Novitasari, S. (2020). Mewujudkan Kemandirian Belajar melalui Pembelajaran Berbasis Daring diperguruan Tinggi pada Era Industri 4.0. *Jurnal Pendidikan Glasser*, 4(1), 64–71. <https://doi.org/10.32529/glasser.v4i1.373>
- Solihin, A. O., Ginanjar, A., & Budiman, A. (2022). The Involvement of Preservice Teachers in Delivering of Sport Education. *KINESTETIK: Jurnal Ilmiah Pendidikan Jasmani*, 6(1), 60–69. <https://doi.org/10.33369/jk.v6i1.20641>
- Stengel, B. S. (2024). *Responsibility Philosophy of Education in Practice*. Bloomsbury Publishing Plc.
- Stran, M., Sinelnikov, O., & Woodruff, E. (2012). Pre-Service Teachers' Experiences Implementing a Hybrid Curriculum: Sport Education and Teaching Games. *European Physical Education Review*, 18(3), 287–308. <https://doi.org/10.1177/1356336X12450789>
- Wallhead, T., & O'sullivan, M. (2005). Sport Education: Physical Education for the New Millennium? *Physical Education & Sport Pedagogy*, 10(2), 181–210. <https://doi.org/10.1080/17408980500105098>
- Wallhead, T., & O'sullivan, M. (2007). A Didactic Analysis of Content Development during the Peer Teaching Tasks of a Sport Education Season. *Physical Education & Sport Pedagogy*, 12(3), 225–243. <https://doi.org/10.1080/17408980701610177>
- Watson, D. L., Newton, M., & Kim, M.-S. (2003). Recognition of Values-Based Constructs in a Summer Physical Activity Program. *The Urban Review*, 35(3), 217–232. <https://doi.org/10.1023/A:1025781603097>
- Wulandari, S., & Hendrayana, Y. (2021). The Influence of Sport Education Model on Responsibility in Basketball Games. *Journal of Physical Education for Secondary Schools*, 1(352), 15–19. <https://doi.org/10.17509/jpess.v1i1.33138>